

MINI RITTER

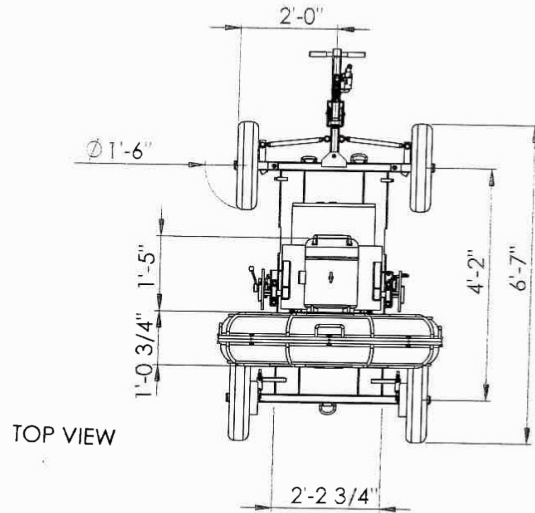

TOP VIEW

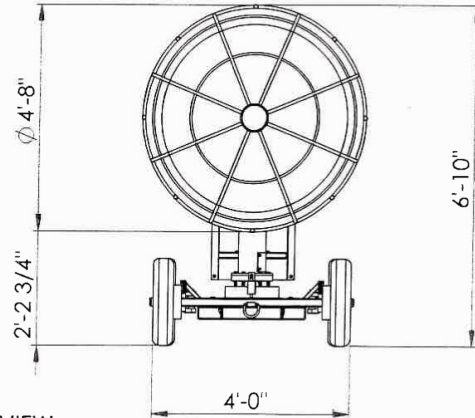

FRONT VIEW

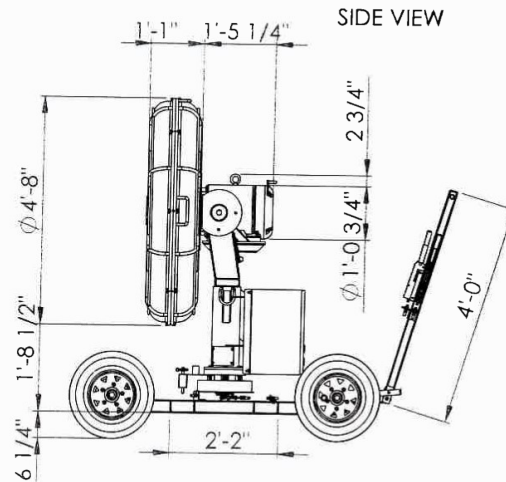

SIDE VIEW

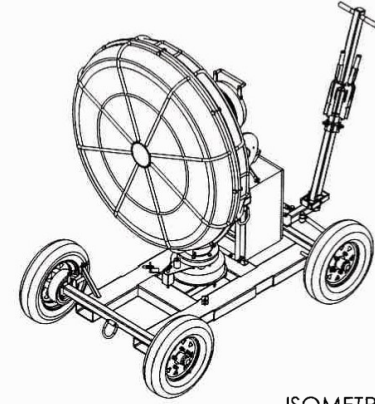

ISOMETRIC VIEW

MINI RITTER	
GROSS WEIGHT:	1500 LBS.
VOLTAGE:	220V POWER SOURCE
AMPERAGE:	40 AMPS PER LEG
PHASE:	SINGLE PHASE W/CAMLOCK PLUGS
HP:	10 HP.
REQUIREMENTS:	REQUIRES A QUALIFIED OPERATOR & MUST BE TIE DOWN VIA RATCHET STRAPS.(NOT PROVIDED) REMOTE CONTROL COMPATIBLE

J.E.M. F/X Inc.
SPECIAL EFFECTS DESIGN & FABRICATION

28255 Kelly Johnson parkway, Valencia CA.91355
(661) 702-1022 OFFICE

THIS DOCUMENT CONTAINS COPYRIGHTED MATERIAL AND CONFIDENTIAL TRADE SECRET INFORMATION BELONGING EXCLUSIVELY TO JEM F/X INC. USE, DISCLOSURE, DISSEMINATION OR REPRODUCTION OF ANY OF THE INFORMATION CONTAINED HEREIN MAY RESULT IN LIABILITY UNDER APPLICABLE LAW.
The date in this document incorporates property rights of ELIA P. POPOV.
Any party copying this document does so in confidence and agrees that it should not be duplicated in a whole or in part, nor disclosed in whole or in part, without the consent of ELIA P. POPOV.

MINI RITTER

DRAWN BY	SIZE	DATE	DRAWING NO	REV
H. GARCIA	D	04/11/19	MINI RITTER 001	N/A
DESIGNED BY	SCALE	FILE NO	SHEET	
JEM F/X	NS		OF	